

# Other flap fittings

- ▶ Flap support
- ▶ KLS 10

## KLS 10



- ▶ For wooden front panels or framed wooden front panels
- ▶ Flap weight including handle max. 6 kg
- ▶ The flap is held open by a catch which is released when the flap is lifted slightly.
- ▶ Flap dimensions: height max. 500 mm / width max. 600 mm
- ▶ Suitable for use on the right
- ▶ Concealed hinges must be fitted at the top of the flap, please order separately
- ▶ Steel, nickel plated / plastic, white

Page reference:

- ▶ For concealed hinges, see page 25

Order no.	PU
0 013 239	1/10 ea.

## Flap and opening dimensions

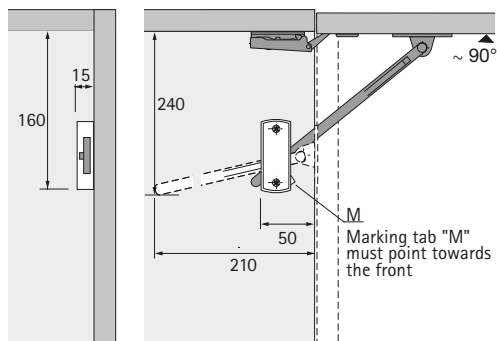

## Carcase drilling pattern

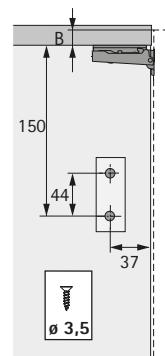

## Flap drilling pattern

