

### Quality that meets all the demands

The quality of the drawer systems is monitored continuously. Hettich fittings comply with the national and international quality standards of the markets our customers operate in. The diagrams below show some of the tests Hettich fittings are required to pass.

#### Application

Hettich drawer systems are suitable for use in living room, kitchen, bathroom and office furniture both in the home and business environment.

#### Load capacity and pull-out guard

The load capacity (to DIN EN 15338) stated in the catalogue is understood to mean the weight of the drawer itself including front panel and contents in kg. The applicable level is shown on the product. Load capacity relates to a reference length of 500 mm. The load capacity may vary for other nominal lengths. All Hettich drawer

systems feature guards to prevent the drawer from rolling out and being removed unintentionally and meet the requirements of the impact test in a test frame to EN 15338. Fitted in the proper manner, the drawer systems are suitable for furniture defined in EN 14749. The maximum front panel height is governed in particular by material, drawer size and drawer runner. Testing is conducted on drawers with a 130 mm front panel height and pot-and-pan drawers with a 300 mm front panel height. We will be pleased to provide any further information you may require.

#### Corrosion test

Hettich runner systems satisfy the requirements on corrosion defined in EN 15338, 72-hour condensation water test to EN 6270.

### Wear test

The fully laden drawer must remain in proper working order after a defined number of opening and closing operations at a defined test velocity.

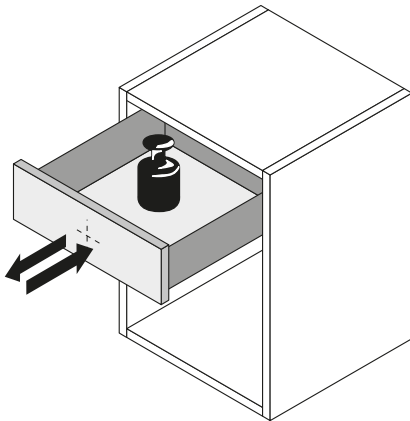

### Retention-on-opening test

The fully laden drawer is abruptly opened all the way several times at a defined test velocity.

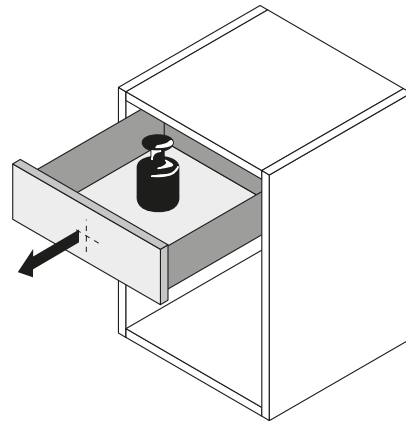

### Horizontal load test

Opened all the way, the fully laden drawer is additionally exposed to horizontal strain with a defined lateral force.

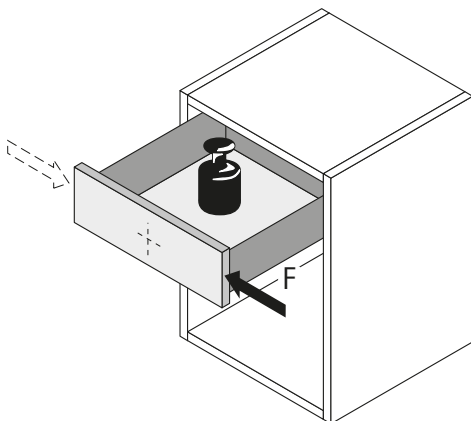

### Vertical strain test

Opened all the way, the drawer is additionally exposed to vertical strain with a defined eccentric force.

